

CERTIFIED QUALITY

Manufacturer and product approvals

When it comes to its areas of utilization, the KLINGER KVN piston valve leaves no questions unanswered. This is confirmed by a wide range of tests and certifications, meaning plant operators can rely on absolute operational safety and a guaranteed tightness of seals.

» **Fire-Safe**

The Fire Safe test in accordance with the API standard and DIN EN ISO 10497 has been certified by Lloyd's Register and the TÜV Austria respectively.

» **Valve for oxygen service**

The BAM Berlin confirms the resistance to internal burnout under the influence of oxygen pressure surges. This refers to utilizing the KVN piston valve at up to 40 bar and operating temperatures of up to 60 °C.

» **Valve on the basis of "TA Luft"**

The requirements of the "TA Luft" regarding the permissible leakage rates at the spindle passage have been fulfilled.

» **Emission testing**

The ISO 15848 and VDI 2440 emission tests for KLINGER KVN piston valves at ≥ 250 °C have been certified by the TÜV Austria.

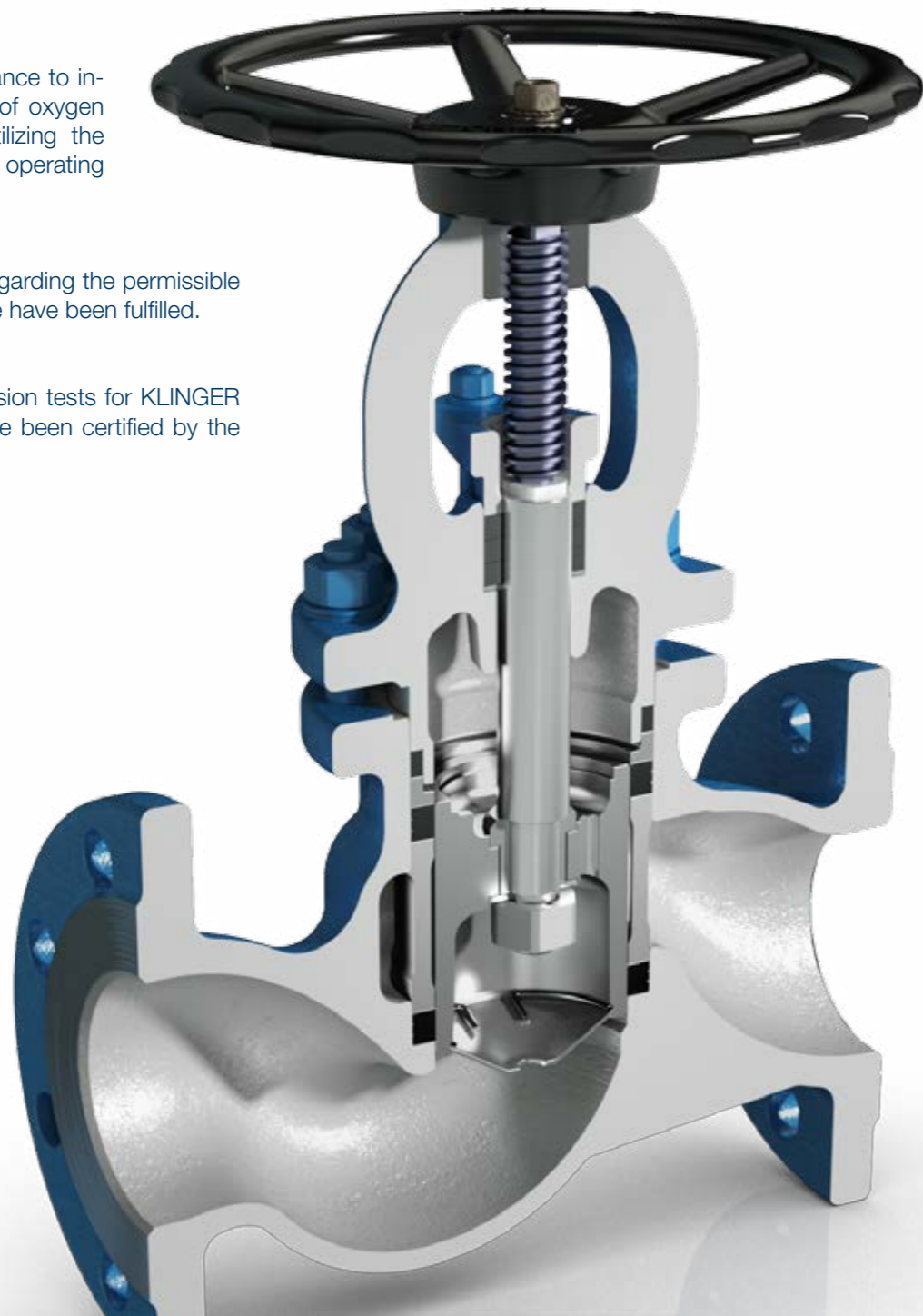

KLINGER KVN

Overview of types

» KVN DN 15-50
Flange design



» 10 » KVN DN 65-200
Flange design



» 11

» KVN DN 65-150
Flange design



» 12 » KVN 1/2"-8"
ANSI design



» 13

» KVMN 1/2"-2"
Sleeved design



» 15 » KVSN 1/2"-2"
Butt and socket weld ends



» 16

KVN DN 15-50

Flange design

GENERAL FEATURES

- » Straight-through piston valve
- » Sealing via two elastic KX-GT valve rings
- » Excellent control characteristics
- » Fire Safe
- » Special regulating design available (KVRKN)

CONNECTIONS

Flange in accordance with EN 1092-2 (Mat. code III, VI)
Flange in accordance with EN 1092-1 (Mat. code VIII, Xc)

DIMENSIONS

EN 558-1, GR. 1

ACCEPTANCE TESTING

- » Seat leak tightness: EN 12266-1 P12, leakage rate A
- » Tightness to atmosphere: EN 12266-1 P11
- » Strength: EN 12266-1 P10

TEMPERATURE

-10 °C to +400 °C (see P-T diagram)

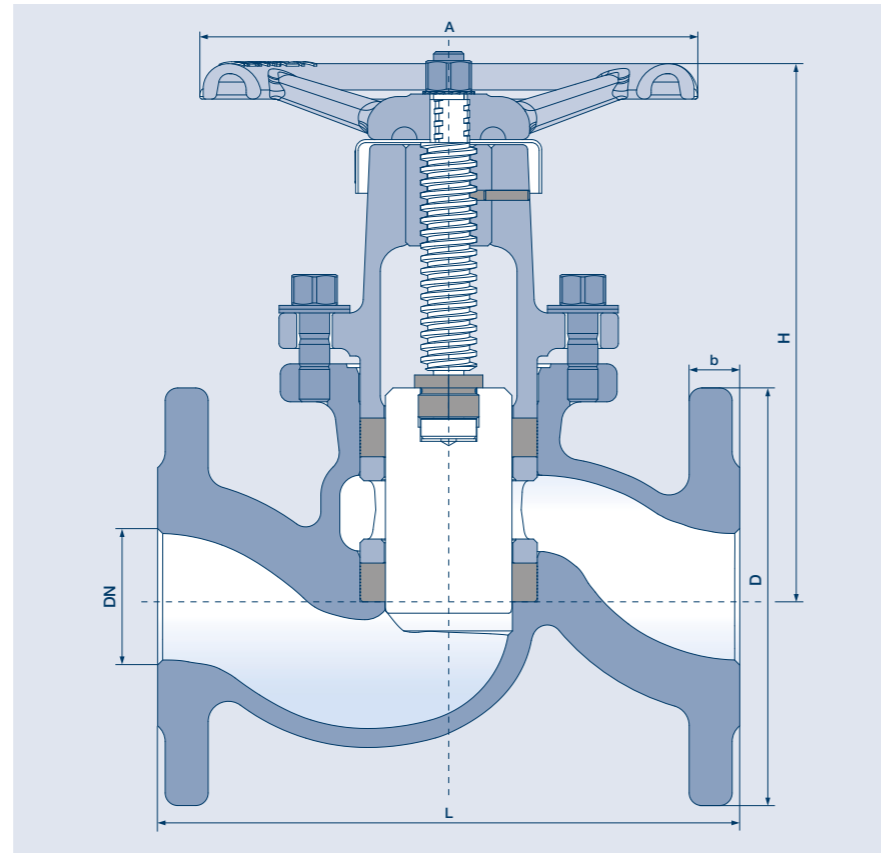

KVN FLANGE DESIGN DN 15-50

MATERIAL

- » Grey cast iron EN-GJL-250 / 5.1301 (Material code III)
- » Nodular cast iron JS 1049 / 5.3103 (Material code VI)*
- » Cast steel 1.0619 (Material code VIII)
- » Stainless steel 1.4581 (Material code Xc)

* refers to body, upper parts consist of VIII

DN	Dimensions							PN			
	L	H	A	D	b PN 16	b PN 40	Hub	III	VI	VIII	Xc
15	130	105	100	95	14	16	23	16	40	40	40
20	150	122	120	105	16	18	28	16	40	40	40
25	160	140	140	115	16	18	34	16	40	40	40
32	180	157	160	140	18	18	38	16	40	40	40
40	200	184	180	150	18	18	45	16	40	40	40
50	230	211	200	165	20	20	51	16	40	40	40

DN	Weight in kg	
	PN 16	PN 40
15	2.8	2.7
20	4.1	4.4
25	5.8	6
32	8.5	9
40	11.2	11.4
50	15.8	16.6

15	2.8	2.7
20	4.1	4.4
25	5.8	6
32	8.5	9
40	11.2	11.4
50	15.8	16.6

Dimensions in mm. Subject to construction and design changes.

KVN DN 65-200

Flange design, pressure-balanced piston

GENERAL FEATURES

- » Piston valve with bore
- » Pressure-balanced design
- » Sealing via three elastic KX-GT valve rings
- » Excellent control characteristics
- » Fire Safe
- » Special regulating design available (KVRLN)

CONNECTIONS

Flange in accordance with EN 1092-2 (Mat. code III, VI)
Flange in accordance with EN 1092-1 (Mat. code VIII)

DIMENSIONS

EN 558-1, GR. 1

ACCEPTANCE TESTING

- » Seat leak tightness: EN 12266-1 P12, leakage rate A
- » Tightness to atmosphere: EN 12266-1 P11
- » Strength: EN 12266-1 P10

TEMPERATURE

-10 °C to +400 °C (see P-T diagram)

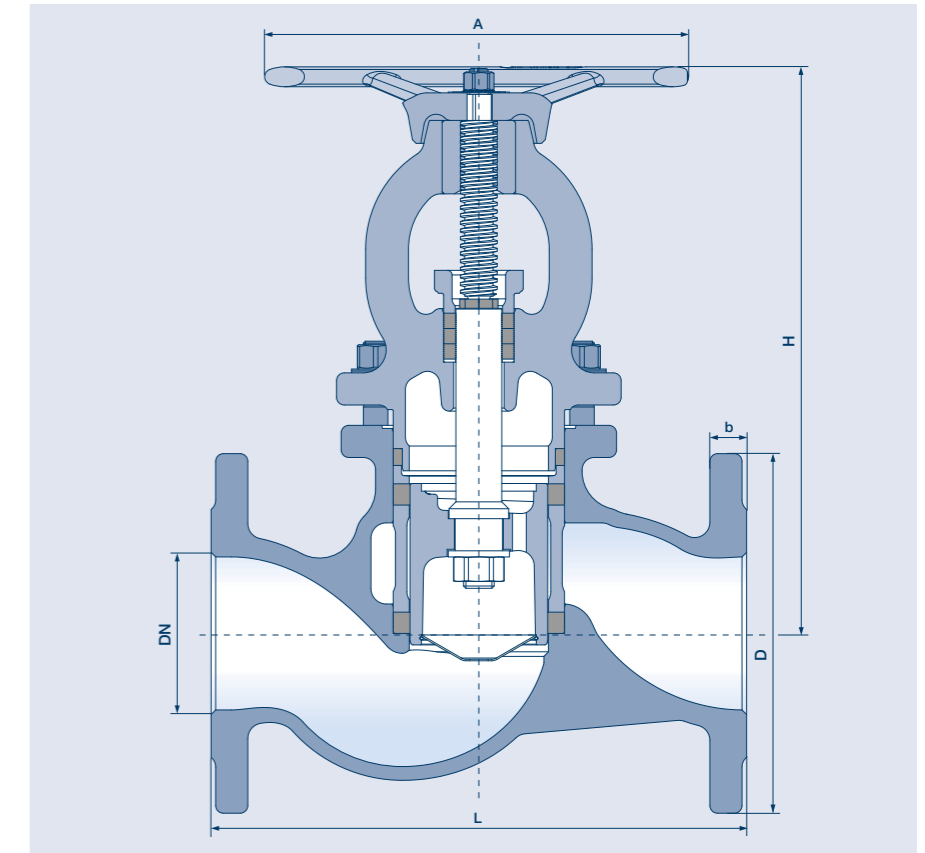

KVN FLANGE DESIGN DN 65-200

MATERIAL

- » Grey cast iron EN-GJL-250 / 5.1301 (Material code III)*
- » Nodular cast iron JS 1025 / 5.3103 (Material code VI)*
- » Cast steel 1.0619 (Material code VIII)

* refers to body, upper parts consist of VIII

DN	Dimensions			PN 16			PN 40			PN			Weight in kg	
	L	H	A	D	b	Hub	D	b	Hub	III/VIII	VI/VIII	VIII	PN 16	PN 40
65	290	306	250	185	20	47	185	22	47	16	16	40	25	26
80	310	324	250	200	22	57	200	24	57	16	16	40	32	33
100	350	370	280	220	24	63	235	24	63	16	16	40	45.5	46
125	400	441	400	250	26	83	270	26	83	16	16	40	68	72.5
150	480	467	400	285	26	93	300	28	93	16	16	40	95	104.5
200	600	560	400	340	30	116	375	34	116	16	16	40	162	178

Dimensions in mm. Subject to construction and design changes.

KVN DN 65-150

Flange design

GENERAL FEATURES

- » Piston valve with bore
- » Sealing via two elastic KX-GT valve rings
- » Excellent control characteristics
- » Fire Safe
- » Special regulating design available (KVRLN)

CONNECTIONS

Flange in accordance with EN 1092-2 (Mat. code III)

DIMENSIONS

EN 558-1, GR. 1

ACCEPTANCE TESTING

- » Seat leak tightness: EN 12266-1 P12, leakage rate A
- » Tightness to atmosphere: EN 12266-1 P11
- » Strength: EN 12266-1 P10

TEMPERATURE

-10 °C to +300 °C (see P-T diagram)

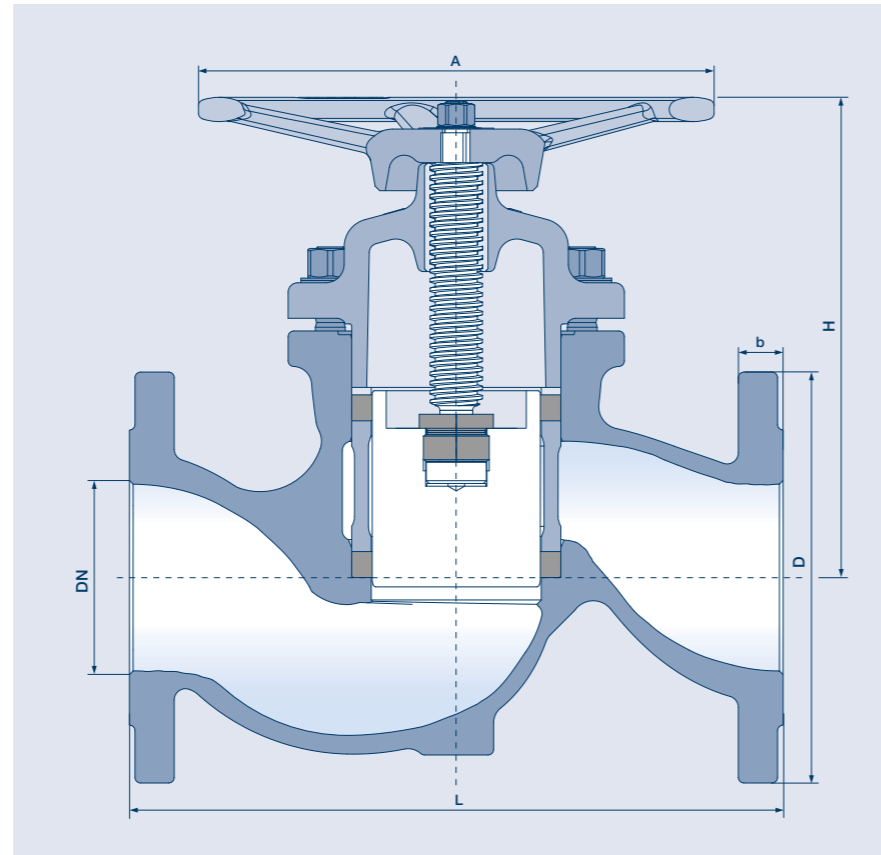

KVN FLANGE DESIGN DN 65-150

DN	Dimensions						PN	Weight
	L	H	A	D	b	Hub		
65	290	189	250	185	20	50	16	23
80	310	214	250	200	22	58	16	30
100	350	257	280	220	24	75	16	43
125	400	298	400	250	26	86	16	69
150	480	328	400	285	26	98	16	96.5

MATERIAL

- » Grey cast iron EN-GJL-250 / 5.1301 (Material code III)

KVN 1/2"-2"

ANSI design, Class 150/300

GENERAL FEATURES

- » Piston valve with bore
- » Sealing via two elastic KX-GT valve rings
- » Excellent control characteristics
- » Fire Safe
- » Special regulating design available (KVRKN)

CONNECTIONS

Flange in accordance with ANSI B 16.5 – Class 150 RF and Class 300 RF respectively

DIMENSIONS

ANSI B 16.10 Class 150 and Class 300 respectively

ACCEPTANCE TESTING

- » Seat leak tightness: EN 12266-1 P12, leakage rate A
- » Tightness to atmosphere: EN 12266-1 P11
- » Strength: EN 12266-1 P10

TEMPERATURE

-10 °C to +400 °C (see P-T diagram)

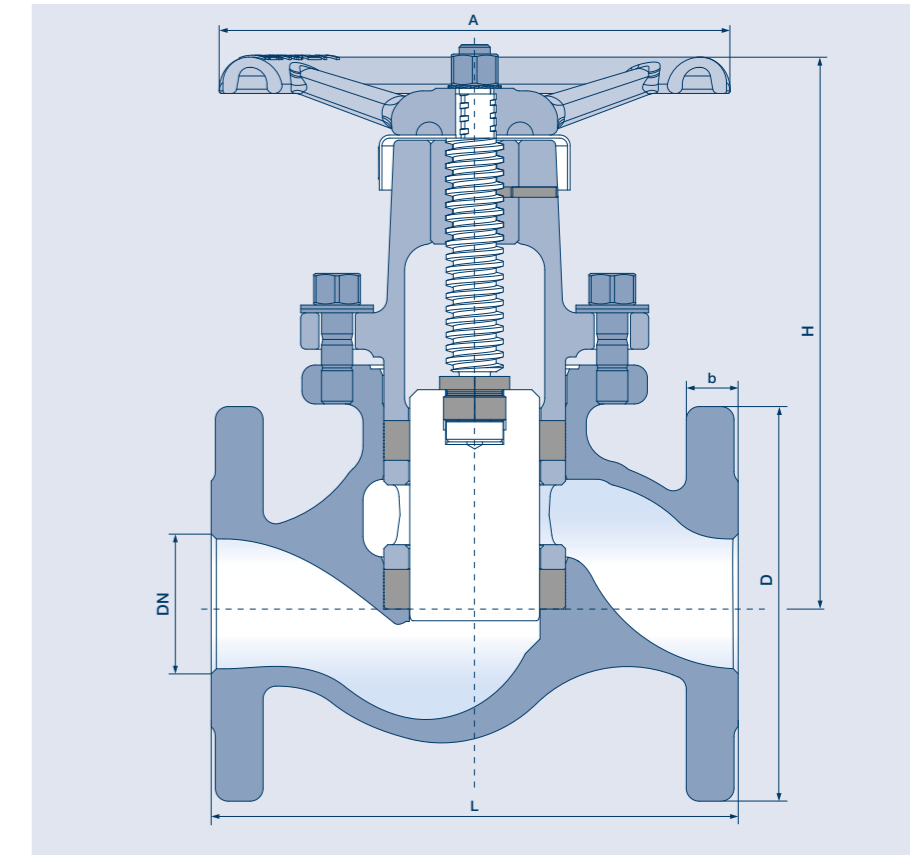

KVN ANSI DESIGN 1/2"-2"

CLASS 150

Material: Cast steel A-216 WCB (Material code VIII)

CLASS 300

Material: Cast steel A-216 WCB (Material code VIII)

DN	Dimensions						Class	Weight
	L	H	A	D	b	Hub		
1/2"	108	105	100	89	12	23	150	2.4
3/4"	117	122	120	99	13	28	150	3.4
1"	127	140	140	108	15.5	34	150	5
1 1/2"	165	184	180	127	18.5	45	150	10.2
2"	203	211	200	152	20	51	150	15.1
1/2"	152	105	100	95	15.5	23	300	3.1
3/4"	178	122	120	118	17	28	300	5
1"	203	140	140	124	19	34	300	7.1
1 1/2"	229	184	180	156	22	45	300	13.4
2"	267	211	200	165	24.5	51	300	18.9

KVN 2 1/2"-8"

ANSI design, Class 150/300

GENERAL FEATURES

- » Piston valve with bore
- » Sealing via two elastic KX-GT valve rings
- » Excellent control characteristics
- » Fire Safe
- » Special regulating design available (KVRLN)

CONNECTIONS

Flange in accordance with ANSI B 16.5 – Class 150 RF and Class 300 RF respectively

DIMENSIONS

ANSI B 16.10 Class 150 and Class 300 respectively

ACCEPTANCE TESTING

- » Seat leak tightness: EN 12266-1 P12, leakage rate A
- » Tightness to atmosphere: EN 12266-1 P11
- » Strength: EN 12266-1 P10

TEMPERATURE

-10 °C to +400 °C (see P-T diagram)

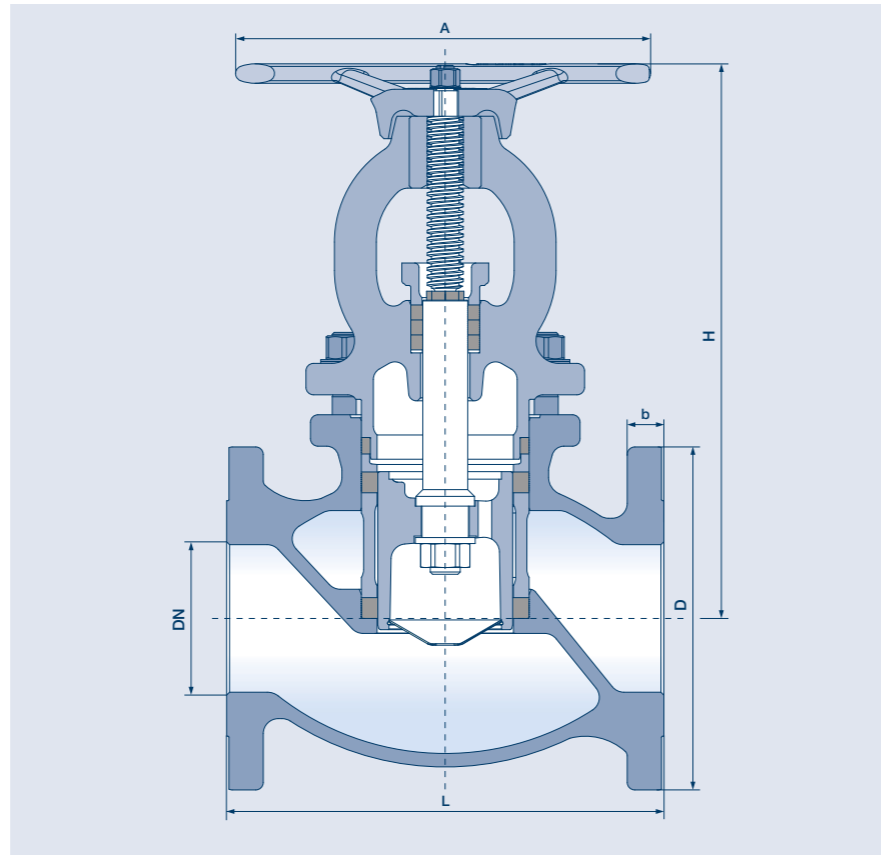

KVN ANSI DESIGN 2 1/2"-8"

CLASS 150

Material: Cast steel A-216 WCB
(Material code VIII)

DN	Dimensions						Class	Weight in kg
	L	H	A	D	b	Hub		
2 1/2"	216	306	250	178	22	47	150	26
3"	241	324	250	191	24	57	150	33
4"	292	370	280	229	24.5	63	150	48.5
6"	406	467	400	280	26.5	93	150	103
8"	495	560	400	345	29	116	150	179.5

CLASS 300

Material: Cast steel A-216 WCB
(Material code VIII)

2 1/2"	292	306	250	191	26	47	300	28
3"	318	324	250	210	29.5	57	300	37
4"	356	370	280	254	32.5	63	300	55
6"	445	467	400	318	38	93	300	114
8"	559	560	400	381	41.5	116	300	193.5

Dimensions in mm. Subject to construction and design changes.

KVMN 1/2"-2"

Threaded sleeve

GENERAL FEATURES

- » Piston valve with bore
- » Sealing via two elastic KX-GT valve rings
- » Excellent control characteristics
- » Fire Safe
- » Special regulating design available (KVRKMN)

CONNECTIONS

DIN sleeved connections with pipe threads in accordance with ISO 228-1 (III, VIII), NPT sleeved connections in accordance with ANSI B2.1 (VIII)

DIMENSIONS

DIN 3202-M9

ACCEPTANCE TESTING

- » Seat leak tightness: EN 12266-1 P12, leakage rate A
- » Tightness to atmosphere: EN 12266-1 P11
- » Strength: EN 12266-1 P10

TEMPERATURE

-10 °C to +400 °C (see P-T diagram)

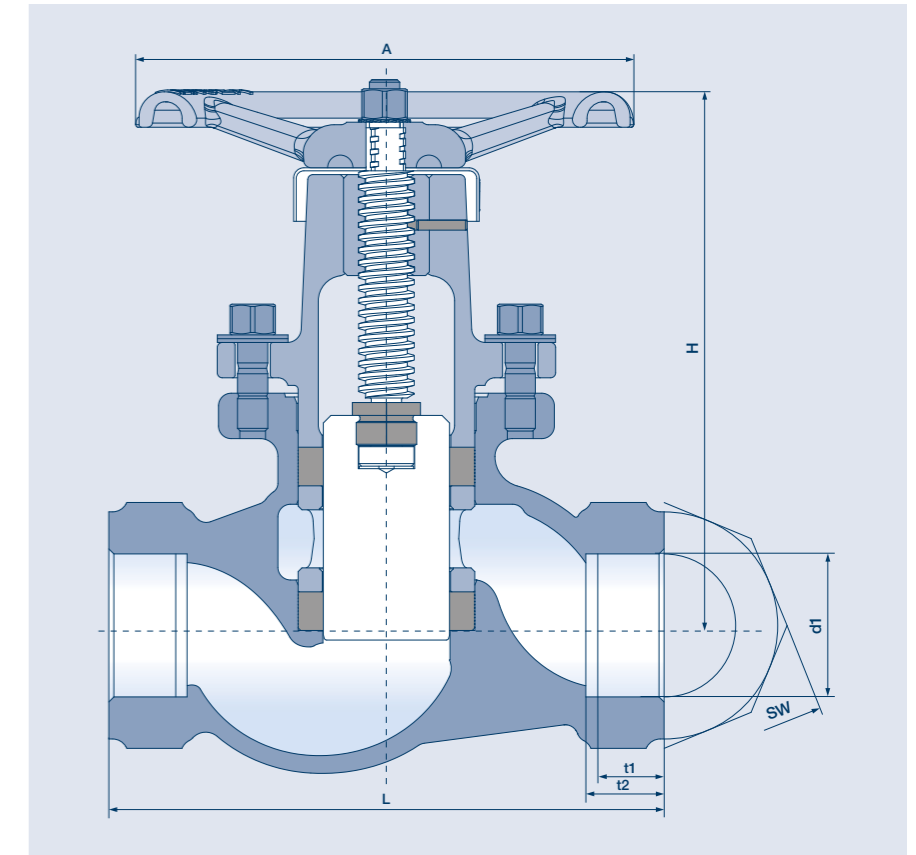

KVMN DESIGN 1/2"-2"

MATERIAL

- » Grey cast iron EN-GJL-250 / 5.1301 (Material code III)
- » Cast steel 1.0619 (Material code VIII)

DN	Dimensions				PN		Weight in kg	
	L	H	A	Hub	III	VIII	PN 16	PN 63
1/2"	100	105	100	23	16	63	1.6	1.8
3/4"	120	122	120	28	16	63	2.5	2.5
1"	135	140	140	34	16	63	3.6	3.7
1 1/4"	160	157	160	38	16	63	5.9	5.9
1 1/2"	185	184	180	45	16	63	8.4	8.6
2"	220	211	200	51	16	63	12.4	13.1

DN	DIN sleeved connections				NPT sleeved connections		
	d1	t1	t2	SW	d1	t1	t2
1/2"	G1/2"	15.5	19.5	36	1/2"-14NPT	13.5	19.5
3/4"	G3/4"	16	20	41	3/4"-14NPT	14	20
1"	G1"	17	22	50	1"-11 1/2NPT	17	24
1 1/4"	G1 1/4"	19	25	65	n.a.	n.a.	n.a.
1 1/2"	G1 1/2"	19	24	75	1 1/2"-11 1/2NPT	17	24.5
2"	G2"	26	31	90	2"-11 1/2NPT	18	25

n.a. – not available

Dimensions in mm. Subject to construction and design changes. NPT sleeved connections only available in cast steel design.

KVSN 1/2"-2"

Socket weld ends

GENERAL FEATURES

- » Piston valve with bore
- » Sealing via two elastic KX-GT valve rings
- » Excellent control characteristics
- » Fire Safe
- » Special regulating design available (KVRKSN)

CONNECTIONS

Socket weld ends in accordance with EN 12760

DIMENSIONS

DIN 3202-M9

ACCEPTANCE TESTING

- » Seat leak tightness: EN 12266-1 P12, leakage rate A
- » Tightness to atmosphere: EN 12266-1 P11
- » Strength: EN 12266-1 P10

TEMPERATURE

-10 °C to +400 °C (see P-T diagram)

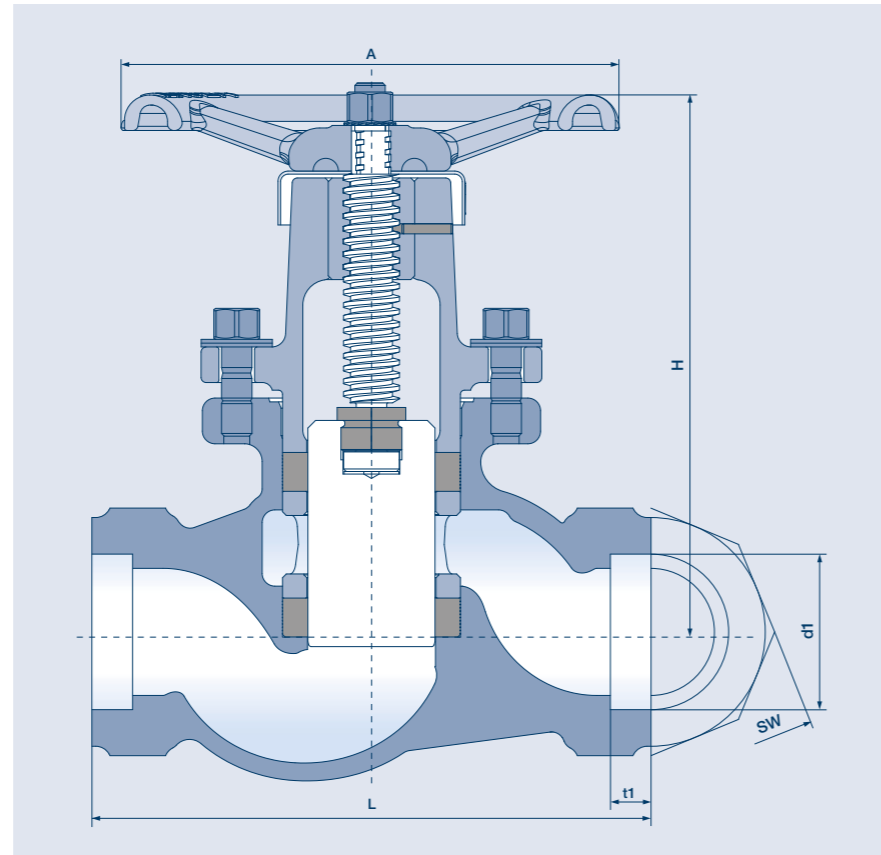

KVSN DESIGN 1/2"-2"

MATERIAL

- » Cast steel 1.0619 (Material code VIII)

DN	Dimensions						Sleeved Connections		Weight in kg
	L	H	A	Hub	d	VIII	t1	SW	
1/2"	100	105	100	23	21.8	63	10	36	1.6
3/4"	120	122	120	28	27.1	63	13	41	2.4
1"	135	140	140	34	33.8	63	13	50	3.7
1 1/4"	160	157	160	38	42.6	63	13	65	5.9
1 1/2"	185	184	180	45	48.7	63	13	75	8.5
2"	220	211	200	51	61.2	63	16	90	13

KVSN DN 15-50

Butt weld ends

GENERAL FEATURES

- » Piston valve with bore
- » Sealing via two elastic KX-GT valve rings
- » Excellent control characteristics
- » Fire Safe
- » Special regulating design available (KVRKSN)

CONNECTIONS

Butt weld ends in accordance with EN 12627

DIMENSIONS

KLINGER Standard

ACCEPTANCE TESTING

- » Seat leak tightness: EN 12266-1 P12, leakage rate A
- » Tightness to atmosphere: EN 12266-1 P11
- » Strength: EN 12266-1 P10

TEMPERATURE

-10 °C to +400 °C (see P-T diagram)

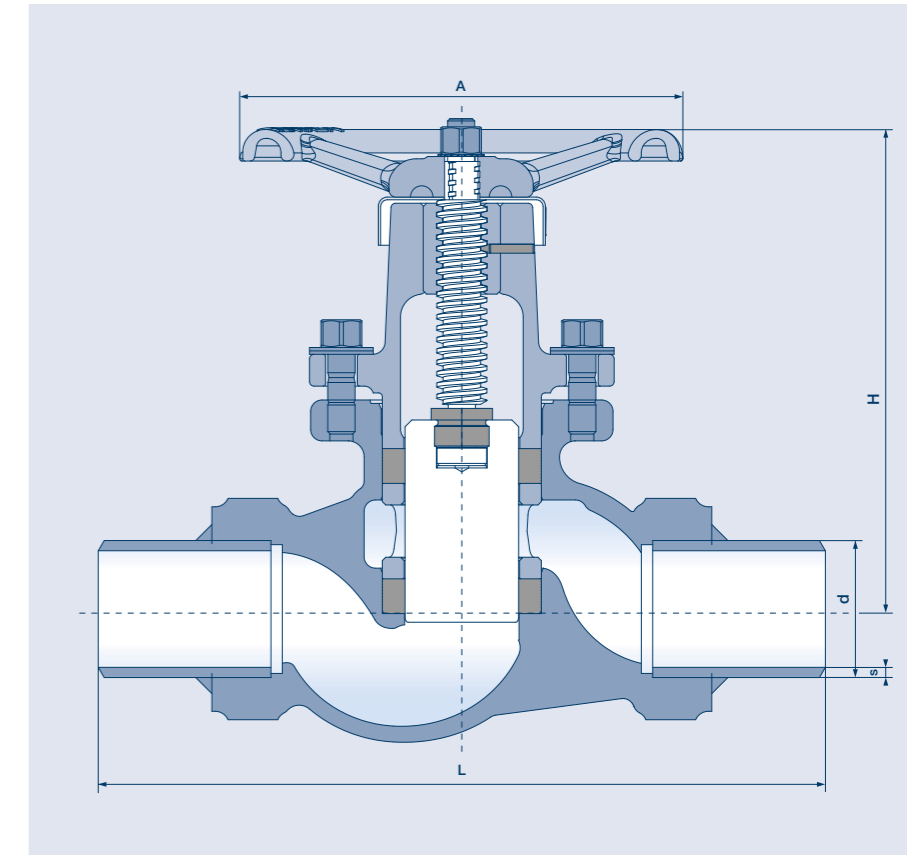

KVSN DN 15-50 DESIGN

MATERIAL

- » Cast steel 1.0619 (Material code VIII)

DN	Dimensions				PN VIII	Mounting dimensions		Weight in kg
	L	H	A	Hub		d	s	
15	145	105	100	23	63	21.3	3.2	1.7
20	170	122	120	28	63	26.9	3.2	2.6
25	200	140	140	34	63	33.7	4	4
32	230	157	160	38	63	42.4	4	6.3
40	270	184	180	45	63	48.3	4	9.1
50	320	211	200	51	63	60.3	4.5	13.9

AREAS OF UTILIZATION

Pressure and temperature diagrams

The pressure and temperature diagrams show the influence of the body and sealing materials on the area of utilization of the piston valve. Insert the operating levels into the diagram fields to identify whether the safety reserves meet your requirements.

DIN STANDARDS

Materials:

- Grey cast iron EN-GJL-250 / 5.1301 (Material code III)
- Nodular cast iron JS 1025 / 5.3103 (Material code VI)
- Cast steel 1.0619 (Material code VIII)
- Nodular cast iron JS 1049 / 5.3103 (Material code VI)
- Stainless steel 1.4581 (Material code Xc)

Pressure ratings:

- PN 63
- PN 40
- PN 16

Pressure-Temperature diagrams
The Pressure-Temperature diagrams allow you to select the most economically feasible KLINGER KVN piston valve.

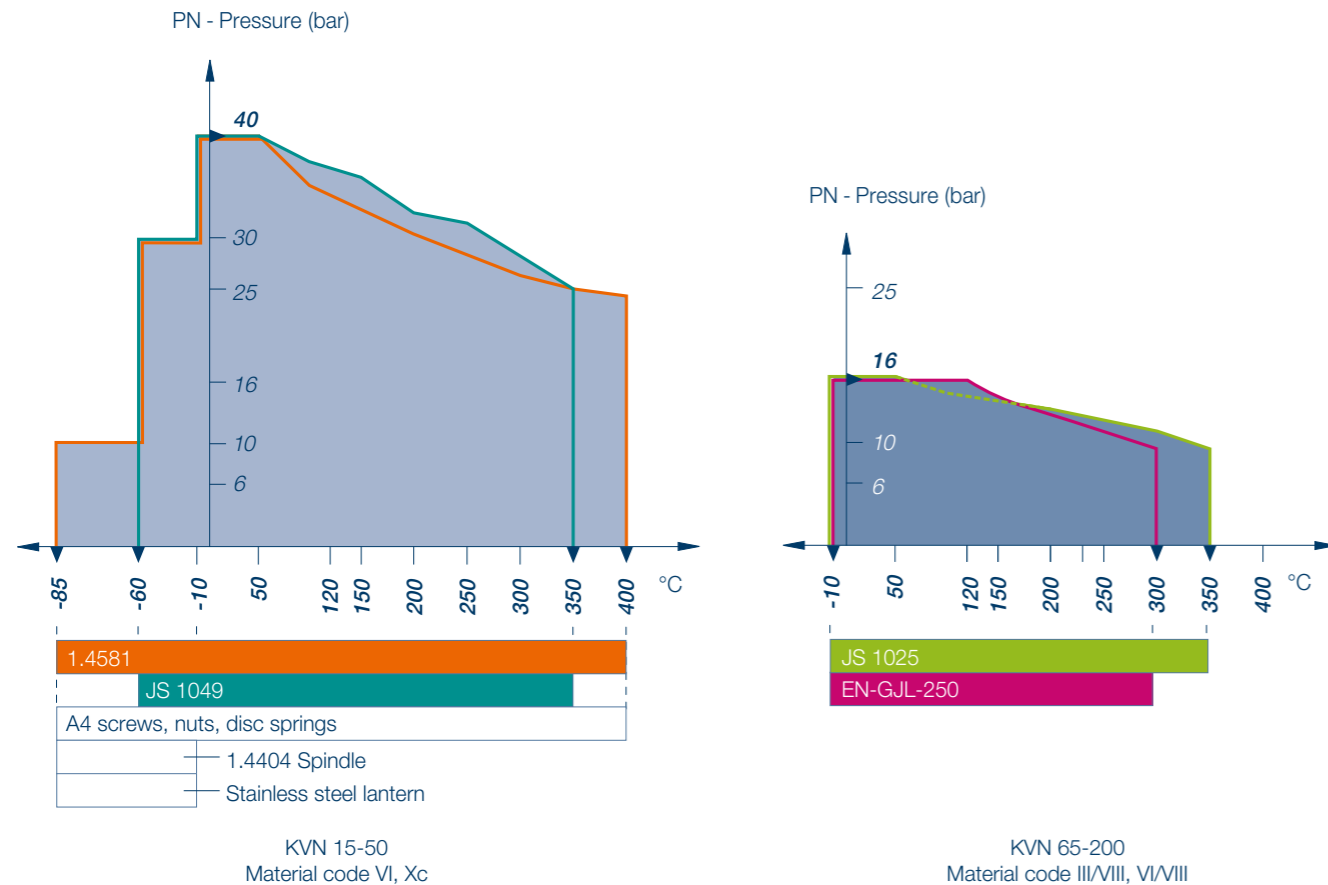
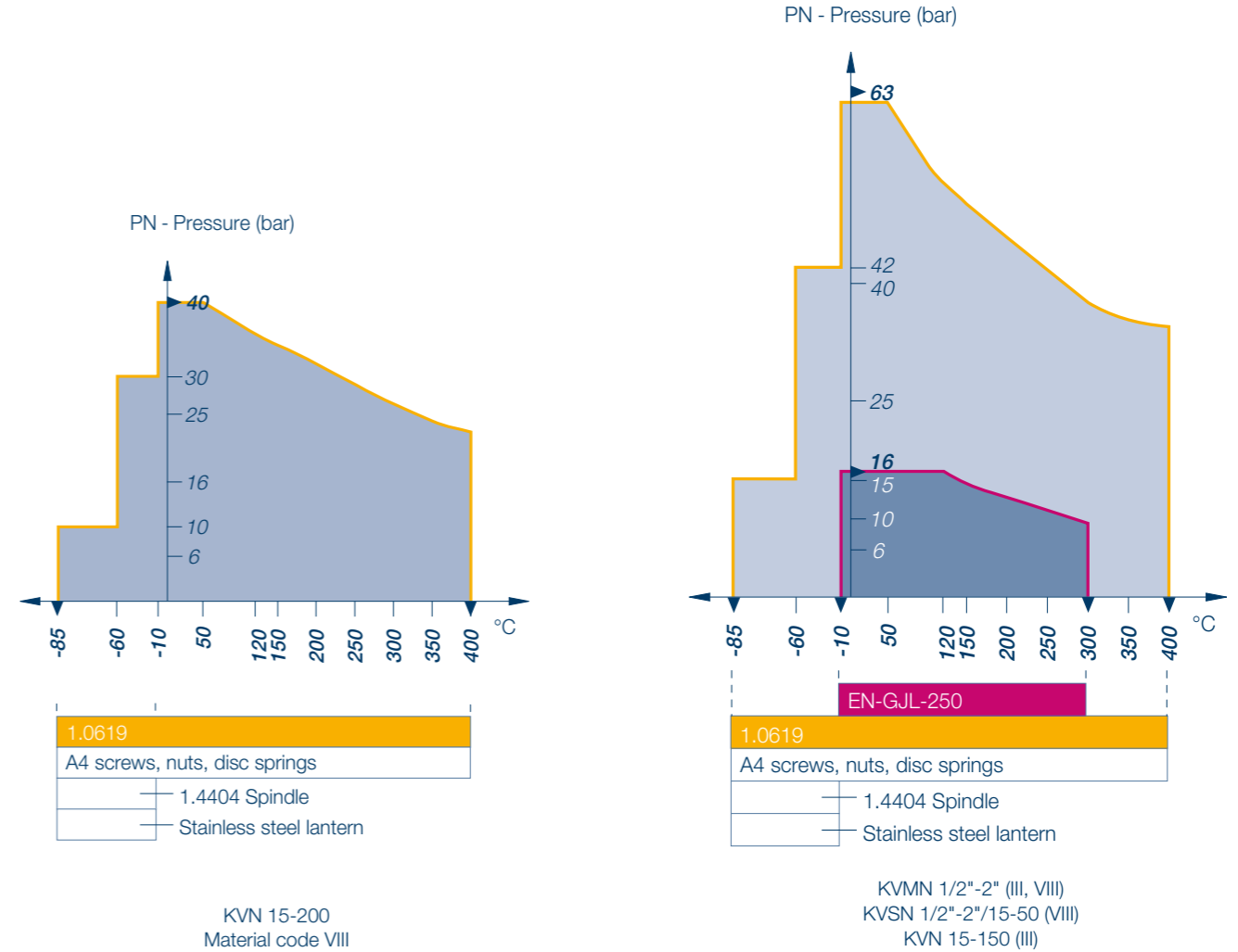

ASME STANDARDS

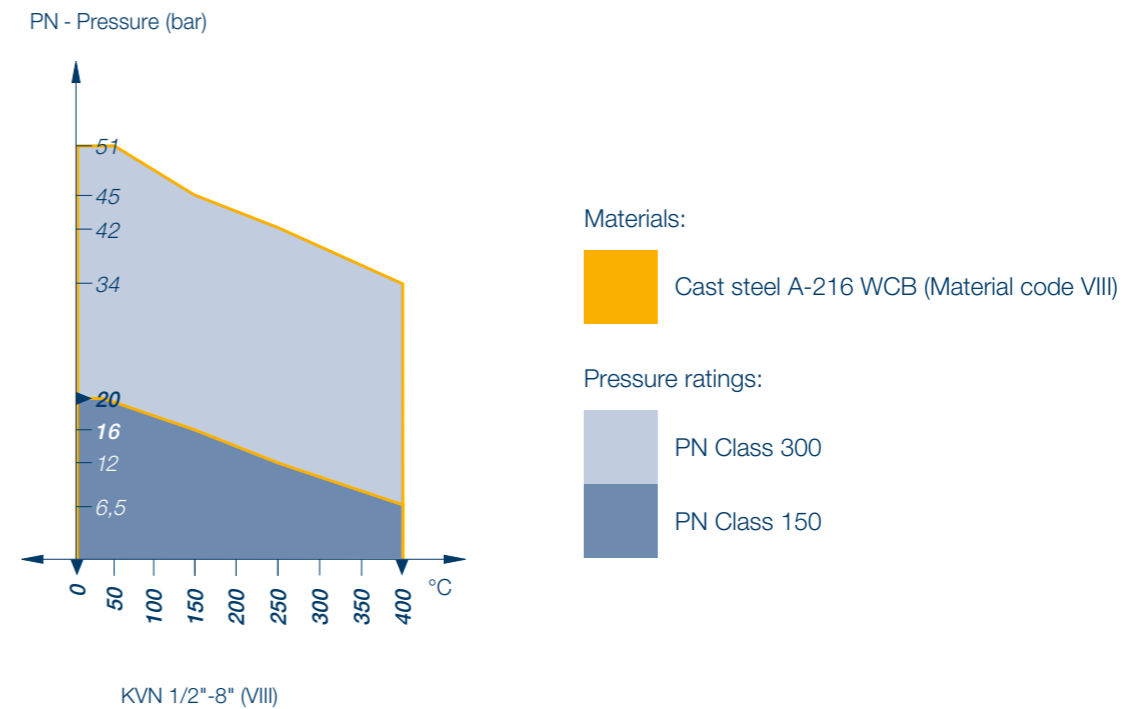

Materials:

- Cast steel A-216 WCB (Material code VIII)

Pressure ratings:

- PN Class 300
- PN Class 150

TECHNICAL DETAILS

Actuator design

KLINGER KVN piston valves can be automated by means of electrical and pneumatic actuators. Multiple designs with an ISO flange can be utilized for automation by means of an electrical actuator. The pneumatic membrane actuator, on the other hand, is directly mounted and is available in a simple or double-acting design. When selecting the actuator, ensure that the actuator is specified with a torque rating corresponding to the nominal size.

Torques

Nominal size DN	Pressure differential	Torque
mm	bar	Nm
15	40	4
20	40	5
25	40	8
32	40	13
40	40	21
50	40	34
65	40	21
80	40	24
100	40	36
125	40	43
150	40	50
200	40	64

Flow values

DN (mm)	ζ	K_{vs} -values
15	4	4.5
20	4	8
25	4	12.5
32	4	20.5
40	4	32
50	4	50
65	6	69
80	6	104
100	6	163
125	7.2	233
150	7.2	335
200	7.2	582

KLINGER Fluid Control recommends the factor 1.5, i.e. using plus 50 % for standard computations.

The characteristic unit for shut-off and control valves in the metric system is the Kv-value. The values provided in the table apply to the H₂O flow medium with a temperature of 5–30 °C, a density of 1000 kg/m³ and a pressure loss of $p = 1$ bar at the valve.

In countries using inches, the characteristic unit is the Cv-value. It provides how many US gal/min of H₂O, at a temperature of 60 °F and with a pressure loss of 1 psi, flow through the valve.

Allows for the calculation of:

$$K_v = Q \cdot \sqrt{\frac{\rho}{1000 \cdot \Delta p}}$$

or

$$\zeta = \frac{2 \cdot \Delta p \cdot 10^5}{\rho \cdot w^2}$$

Flow rate
Pressure loss
Density
Velocity
Flow coefficient
Pressure loss
coefficient

Q in m³/h
 Δp in bar
 ρ in kg/m³
 w in m/s
 K_v in m³/h
 ζ

The valve is to be selected in a manner that the Kv-value is greater, or the ζ -value less than the computed value for the desired application.

KVN AUTOMATION

Optimization and precision

» KVN with mounted actuator

Available either with an electromechanical or a pneumatic actuator.

» Electromechanical actuator

Available for 400 Volt and 230 Volt respectively as well as with special voltage on demand.

» Pneumatic actuator

The pneumatic membrane actuator can be provided in a single as well as in a double-acting design and offers an OPEN/CLOSE function. The single-acting actuator is executed in a manner that allows the valve to be closed by means of spring tension and opened by means of set pressure.



Fig.: KVN with actuator